



# **TECHNICAL SPECIFICATIONS**

## **SERVICE LIFTS MODEL MTH**



<b>APPLICATION</b>	Vertical transport of medium loads for the industry and services sectors. The stop level is even with the wooden floor so as to ensure easy loading of both goods and trolleys. This lift may operate as: <ul style="list-style-type: none"> <li>- Trolley-lift (in laundries, hotels, ...)</li> <li>- Goods-lift (in stores, shops, ...)</li> </ul>
<b>REGULATIONS</b>	The lift fully complies with Machine Directive 98/37/CE, allowing its commercialisation in all the countries of the European Community.
<b>CHARACTERISTICS</b>	
<i>LOAD</i>	<b>MTH 300</b> 200 Kg y 300 Kg <b>MTH 500</b> 400 Kg y 500 Kg
<i>SPEED</i>	<b>Hydraulic</b> 0.2 m/s or 0.3 m/s <b>Electric</b> 0.3 m/s
<i>TRAVEL</i>	<b>Hydraulic</b> Up to 12 mettres. <b>Electric</b> Up to 35 mettres.
<i>STOPS</i>	Up to 12 stops
<i>TIPE OF DRIVE</i>	<b>Hydraulic</b> , Indirect acting lift 2:1. Cylinder, single acting cylinder with internal catch, with safety valve if pipe is broken connected directly to the cylinder. Possibility of rupture valve with progressive closing and external adjustment - optional, must be ordered . Plunger formed by a solid, chromium - plated piston rod. Steel Fe 510 C. Jacket formed by a tube of the appropriate thickness. DIN 2391 tube with BK finish, St-52 steel. Hydraulic power unit, compact power unit made up of oil tank, motor-pump group and block with safety and control devices.  <b>Electric</b> , by traction, using counterweight pulleys. Geared motor in the top of the shaft. Worm gear unit driving by electric motor with brake system.
<i>PIPING</i>	For hydraulic operation <b>Rigid pipe</b> tubes as per DIN 2391, material steel St-37.4 (NBK) - 3 m standard - <b>Flexible</b> , hydraulic hoses with double metallic mesh, tested with couplings fitted – optional on demand –
<i>GUIDES</i>	By 2 rails T65/A in accordance with ISO 7465
<i>SUSPENSION</i>	<b>Hydraulic</b> Single line roller chains according to DIN 8187 MTH-300: 2 chains ½", break force 18.2 KN MTH-500: 2 chains ¾", break force 29.5 KN <b>Electric</b> Cables format 6x19+1 MTH-300: 2 6mm diam. cables, break force 23.8 KN (1770 N/mm <sup>2</sup> ) MTH-500: 2 8mm diam. cables, break force 34.8 KN (1770 N/mm <sup>2</sup> )

**CAR**

**FINISH** **Stainless Steel.** AISI-441, AISI-316 available (food applications)  
**Painted steel.** Baked enamel (epoxi-polyester) paint.  
 Standard colour: Light grey. Enchased texture (rough).

**DIMENSIONS**

Standar			Non standar			
A, B	H		A, B min.	A, B max.	H min.	H max.
x 50	1200		700	1200	800	1400

**A, B** Car depth and wide  
**H** Car height.

**ENTRANCE LAYOUTS** Standard: Layouts 1, 2, 3, 4, and 6.

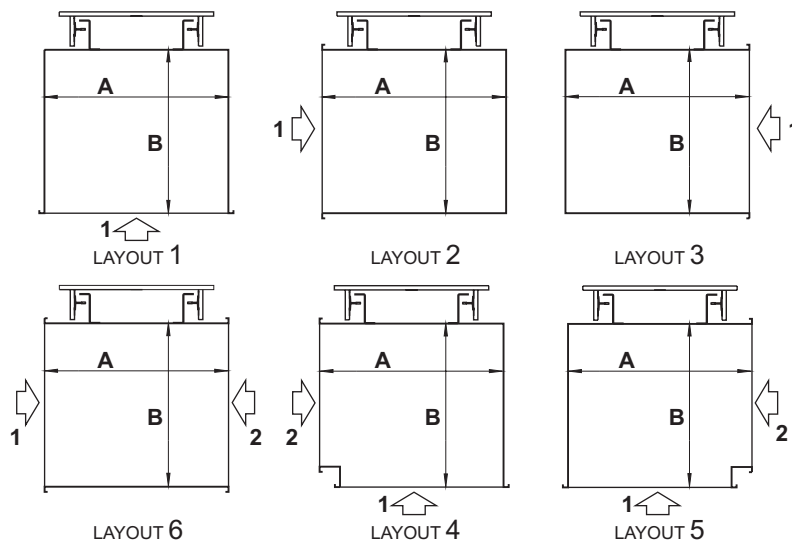

**INTERMEDIATE TRAYS** Collapsible intermediate trays of painted plate sheet or stainless steel (available on request).

**CAR DOORS** Drop bar avoiding moving of load out of the cabine.  
 Sash or bellow-type grid doors available.

**LANDING DOORS**

Swing hinged doors as standard supply; vertical bi-parting doors available.  
 Our landing doors have mechanical locks with two electrical safety devices: Closed door contacts and lock contacts. We supply electrical cam (230V AC) for acting the landing door locks.

**FINISH**  
**Stainless Steel.** AISI-441, AISI-316 available (food applications)  
**Painted steel.** Baked enamel (epoxi-polyester) paint.  
 Standard colour: Light grey. Enchased texture (rough).

**DIMENSIONS** Clear opening according to entrances layout and car dimensions (See Figures 1,2, 3, and 4).  
 Clear height is the same as car height (H).

**FIRE RATED** All swing hinged doors are fire rated (PF-60).  
 Fire rated vertical bi-parting doors available – optional, on demand -  
 If the doors finish is painted steel they are supply with a fireproof priming paint.

**AUTOMATIC OPERATION** Sash type available on request.  
 Automatic opening of doors when the lift car arrives. With pedal to call the lift car or open the door. The door is closed stepping on the pedal or pushing the button corresponding the stop where the lift car is.

**MACHINE ROOM DOOR**

**Hydraulic.** No trapdoor, no hydraulic unit outside the shaft..  
**Electric.** Maintenance trapdoor in the top of the shaft. Single leaf door with standard setting triangle. Dimensions: 500x500 mm. Standard finish, epoxy-polyester paint. Minimum shaft dimensions for proper installation, see figure 1.

**POWER SUPPLY**

230 V ± 5% Single-phase, 50/60 Hz.  
 230/400 V ± 5% Three-phase, 50/60 Hz.  
 Other voltages available.

**CONTROL SYSTEM**

Universal simplex by electrical control board with relays, delay current to 24 V.  
 Buttons panel in the landing doors with push-buttons for calling and sending to all floors; Light indicating engaged, position of lift and landing door open.  
 Accoustic signal on arrival.

**MOTOR POWER**

The maximum power installed and the maximum nominal consumption at 400, depending on load and nominal speed, are as follows:

	200 Kg	300 Kg	400/500 Kg
Hydraulic, 230/400 V 3-phase, v=0,2m/s	1.5 kW / 5.9 A	1.5 kW / 5.9 A	2.2 kW / 8.3 A
Hydraulic, 230/400 V 3-phase, v=0,3m/s	2.2 kW / 8.3 A	2.2 kW / 8.3 A	3.0 kW / 11.2 A
Hydraulic, 230 V Single phase, v=0,2m/s	1.5 kW / 9.8 A	2.0 kW / 14.5 A	-
Hydraulic, 230 V Single phase, v=0,3m/s	2.0 kW / 14.5 A	-	-
Electric, 230/400 V 3-phase	0.55 kW / 1.6 A	0.75 kW / 2.1 A	1.1 kW / 3.2 A
Electric, 230 V Single phase	0.55 kW / 4.5 A	0.75 kW / 6.0 A	1.1 kW / 7.0 A

## INSTALLATION

### *FIXING THE GUIDE RAILS*

#### **Fastening on wall (Standard)**

Everything necessary for bracket mounting to one of the lift shaft walls is supplied; guide rail brackets attached by bolts to concrete or solid brick wall.

For hollow brick walls allowances should be made for built-in metal supports to weld the brackets to, or the use of through-wall pegs if the wall is accessible from both sides.

The reaction forces on the guide rails supports are specified in the assembly instructions.

#### **With self supporting structure (Optional)**

Steel structure, it is painted with waterproof paint. It makes easy the fitting up and allows the enclosures of lift well without masonry work.

Horizontal anchorages to the building are required.

### *ELECTRIC INSTALLATION*

Button panels are supplied fitted in the landing doors frame.

Pre-mounted and ready to plug in, interconnecting different floors by wires with connectors.

### *HYDRAULIC INSTALLATION*

All the necessary piping and couplings are supplied to carry out hydraulic installation. In the case of rigid pipes, this is malleable enough to form any necessary bends, which is why elbow couplings to connect tubes are not supplied

### *MACHINE ROOM*

**Hydraulic:** It is envisaged that the hydraulic power unit shall be positioned no more than 10 metres from where oil inlet to the cylinder; consult us if a greater distance is required.

The dimensions of the central unit and the panel are 390x245x600 mm and 300x400x150 mm respectively.

**Electric:** the traction machine will be installed in the top of the shaft, on two beams when installed on a wall. For that purpose, a trapdoor must be installed so as to ensure access to the machine and carry out safe maintenance.

For easier maintenance operations, the electric box should be located outside the shaft; an electric hose of sufficient length is provided for that purpose. The electric box measures 300 (length) x 400 (height) x 150 (depth).

## SHAFT SIZE

Adapted to entrance layout, car dimensions, operating system and conveying structure option (see figures 1, 2, 3 and 4).

Figure 1. Minimum shaft dimensions.  
 Front view hydraulic.

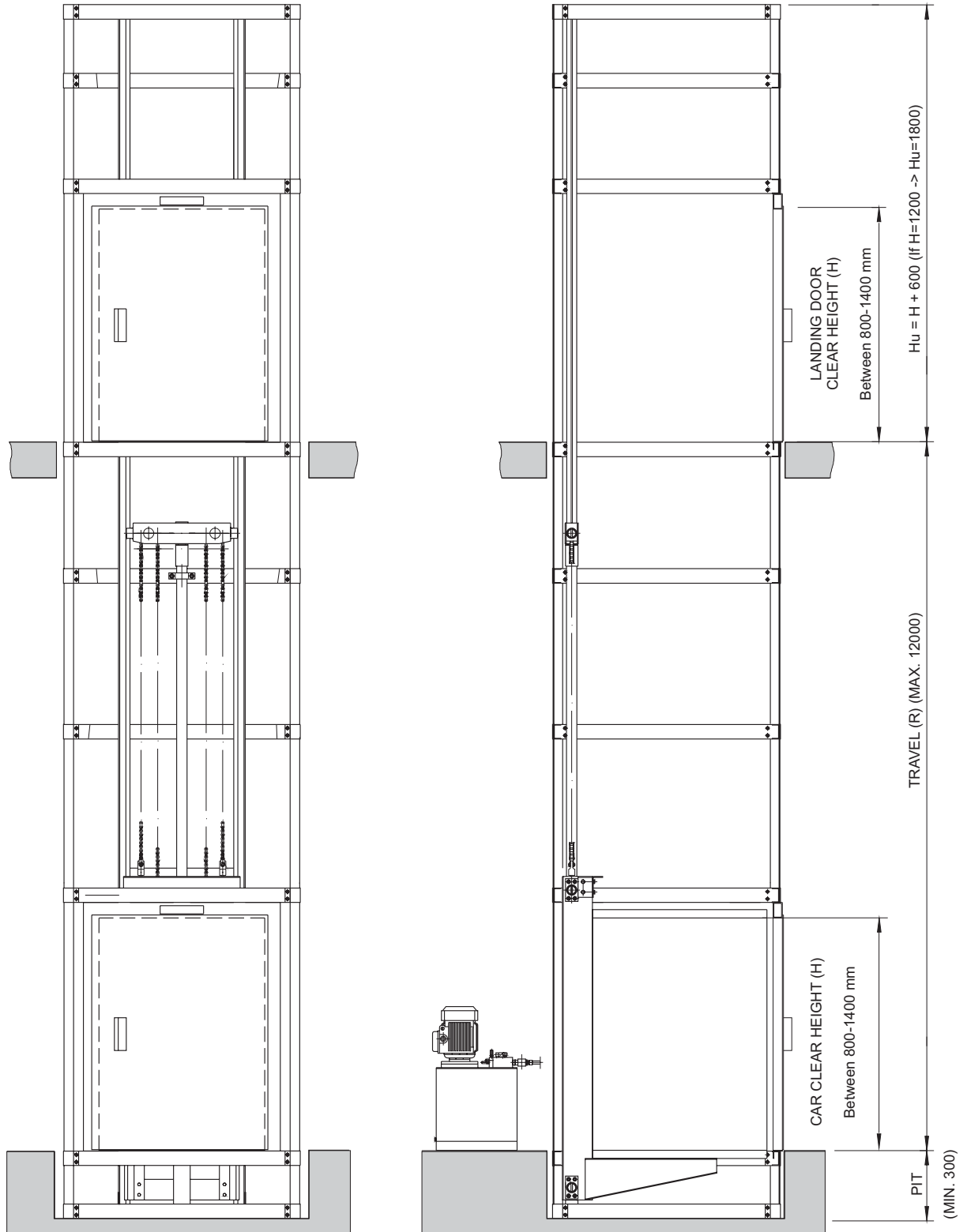

**Figura 2. Minimum shaft dimensions (Front view)**  
*Electric..*

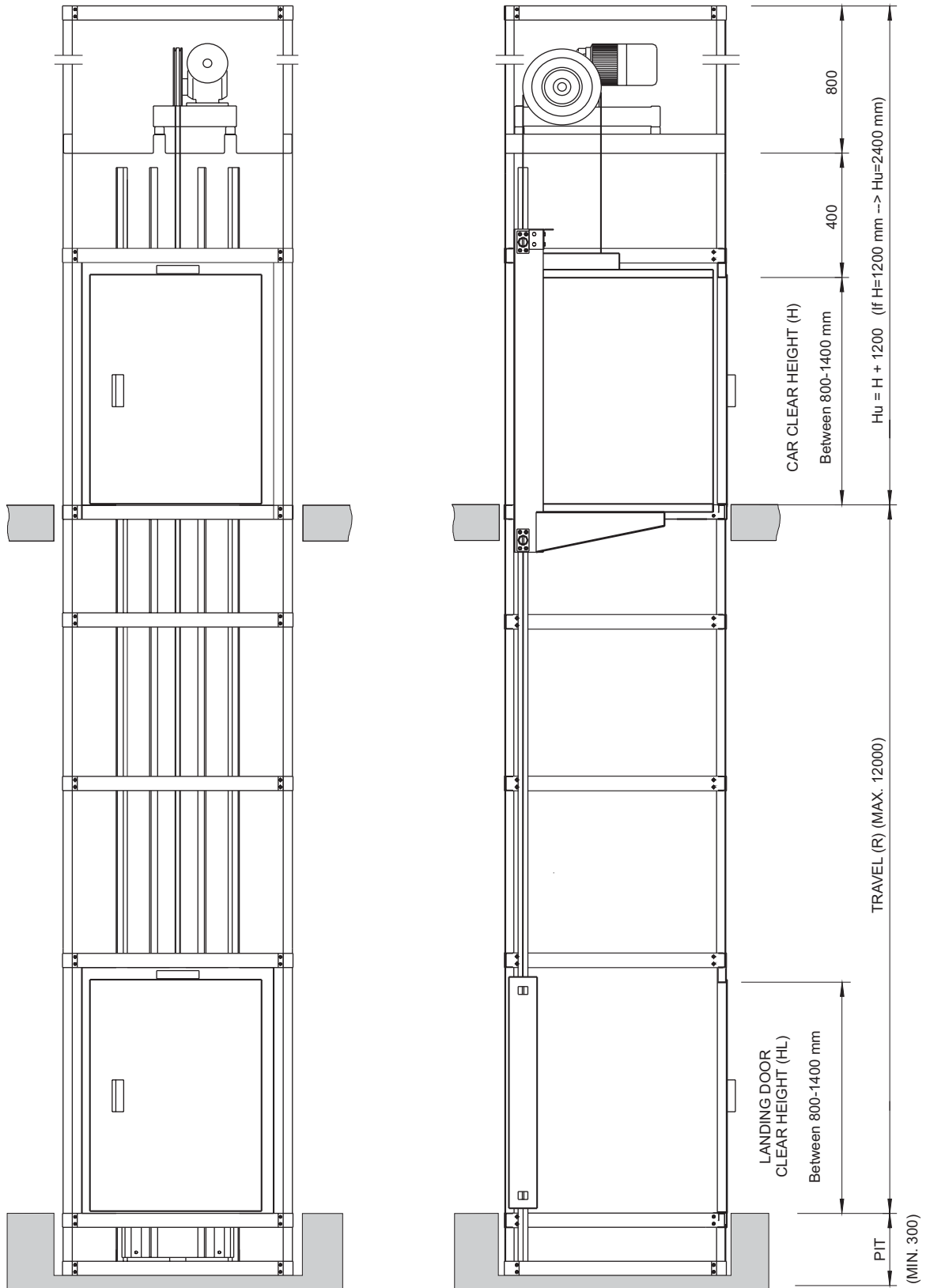



**Figure 3. Minimum shaft size (plan)**  
 Without structure: **Fastening on wall.**

N <sup>er</sup> Layout Cabin MTH	A mm				B mm
	Landing Doors layout 1		Landing Doors layout 2		
	Right Side	Left Side	Right Side	Left Side	
1 (layout frontal)	700 - 1200		-	-	700 - 1200
2 (layout lateral)	1000 - 1200	750 - 1200	-	-	
3 (layout lateral)	750 - 1200	1000 - 1200	-	-	
4 (double layout 90°)	-	1000 - 1200	1000 - 1200	-	
5 (double layout 90°)	1000 - 1200	-	-	1000 - 1200	
6 (double layout 180°)	1050 - 1200	750 - 1200	750 - 1200	1050 - 1200	

Maximum surface (A x B) = 1.2 m<sup>2</sup>

(\*) 90° Double car are available depending on the boarding access and door hand side opening. Take in to consideration the cam can not be placed at corner frame side.

(\*\*) Cam could not be placed at guides side in case of A<1050.

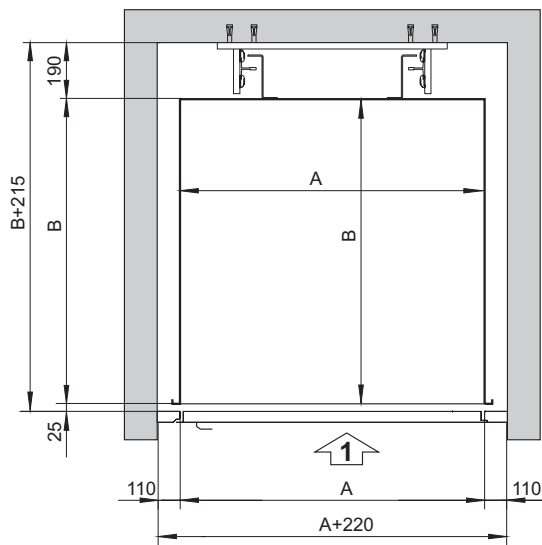

Layout 1

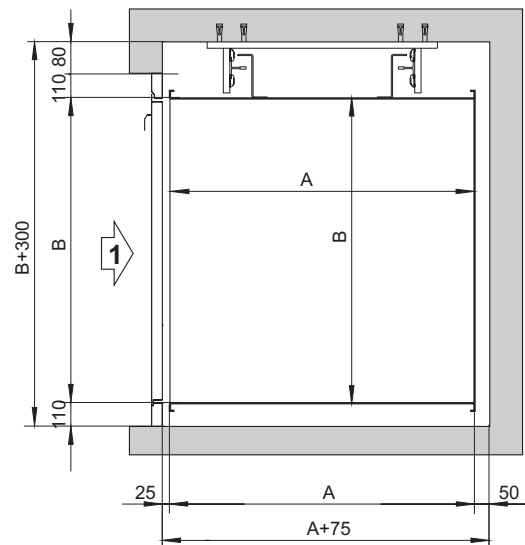

Layout 2-3

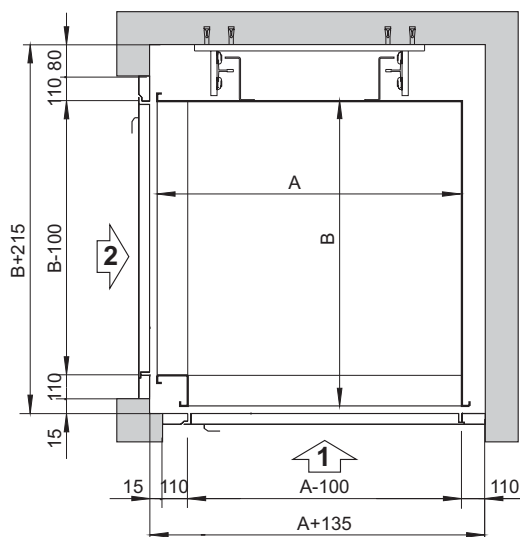

Layout 4-5

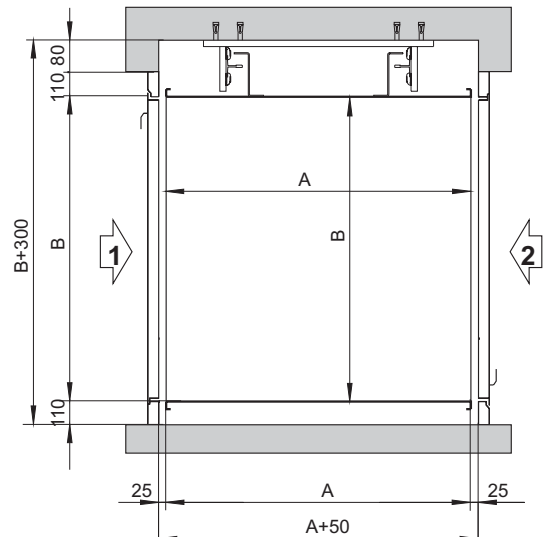

Layout 6

**Figure 4. Minimum shaft size (plan)**  
**With self-supporting structure**

N <sup>er</sup> Layout Cabin MTH	A mm				B mm
	Landing Doors layout 1		Landing Doors layout 2		
	Right Side	Left Side	Right Side	Left Side	
1 (layout frontal)	700 - 1200		-	-	700 - 1200
2 (layout lateral)	1000 - 1200	750 - 1200	-	-	
3 (layout lateral)	750 - 1200	1000 - 1200	-	-	
4 (double layout 90°)	-	1000 - 1200	1000 - 1200	-	
5 (double layout 90°)	1000 - 1200	-	-	1000 - 1200	
6 (double layout 180°)	1050 - 1200	750 - 1200	750 - 1200	1050 - 1200	

**Maximum surface (A x B) = 1.2 m<sup>2</sup>**

(\*) 90 ° Double car are available depending on the boarding access and door hand side opening. Take in to consideration the cam can not be placed at corner frame side.

(\*\*) Cam could not be placed at guides side in case of A<1050.

(\*\*\*) The projection in plant of the landing doors, invades 10 mm the internal projection of the shaft.

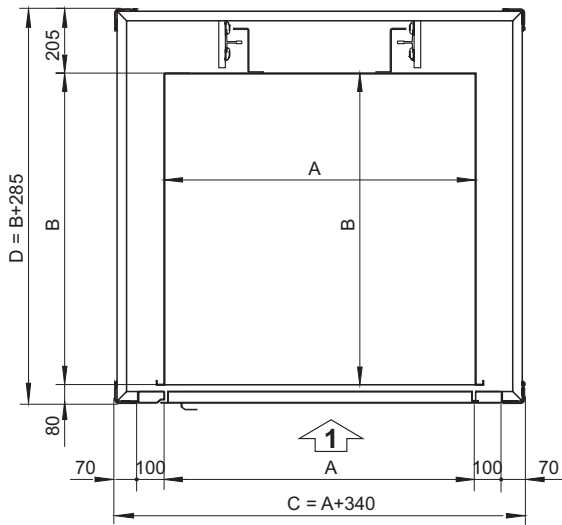

Layout 1

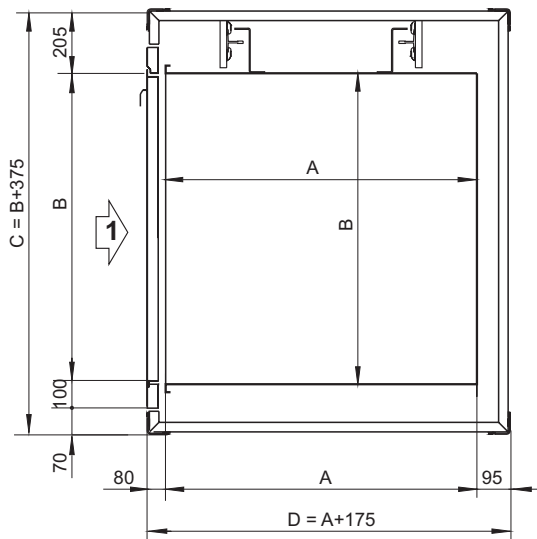

Layout 2 - 3.

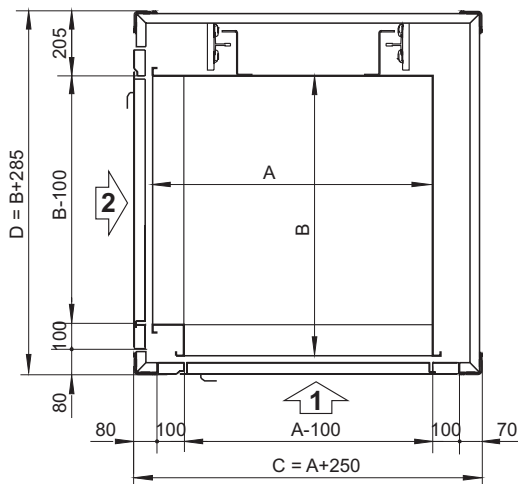

Layout 4 - 5

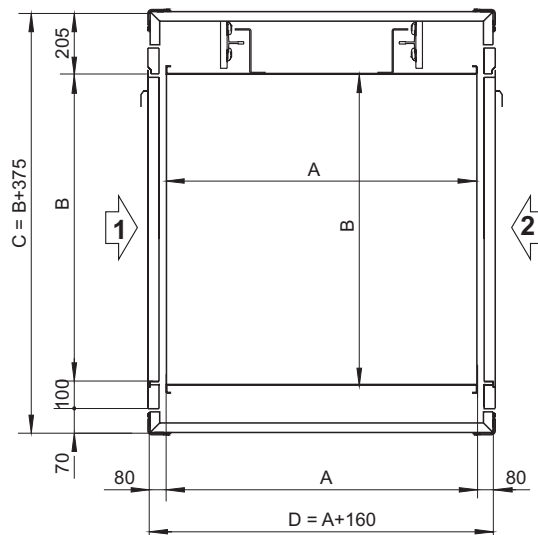

Layout 6



**Hidral, S.A.**

---

Polígono Industrial EL PINO, Parcela 13 E  
41016 SEVILLA - ESPAÑA  
Tlfn.: +34 95 451 45 00 Fax: +34 95 467 76 33  
[www.hidral.com](http://www.hidral.com)